

## SEGNALETICA DI SICUREZZA

*Safety Signs*

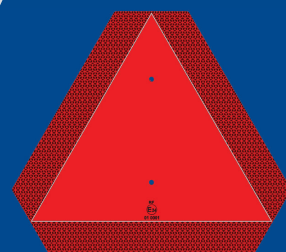
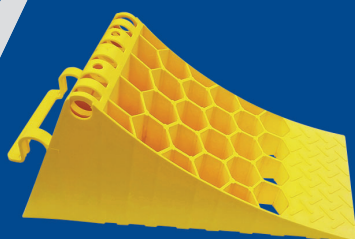

**Ø 200 mm**

Dischi adesivi segnali di velocità per veicoli omologati in pellicola rifrangente cl. 2  
Homologated speed limit self-adhesive discs for vehicles with rear reflecting film cl. 2

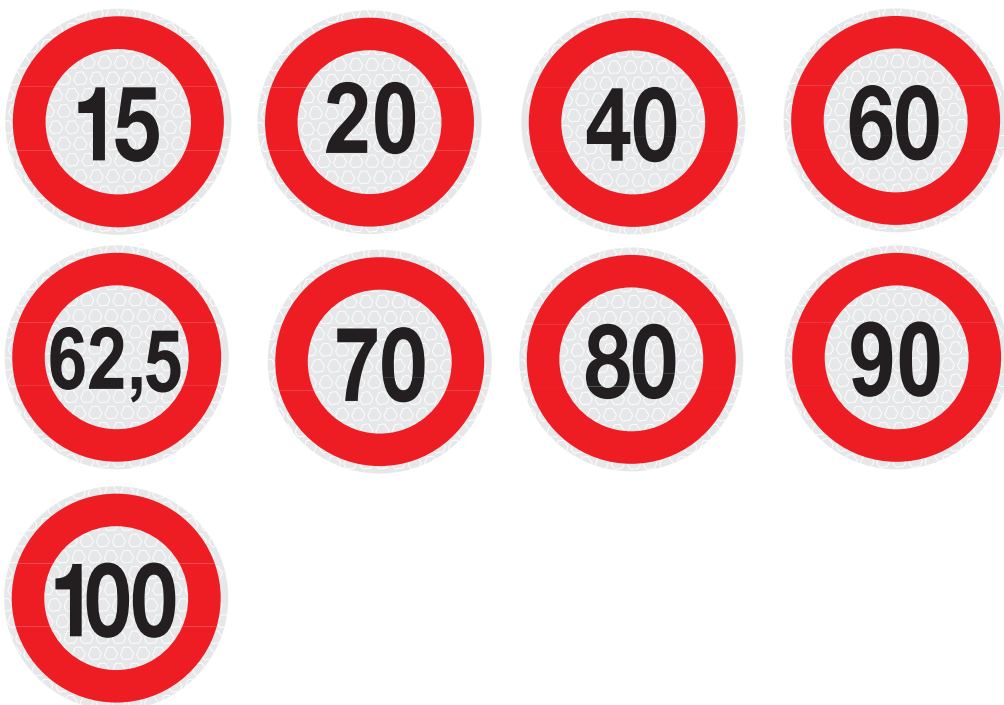

P/N	Q.ta Q.ty	Velocità Speed
<b>1003367</b> AV-06-0042	10	15 Km
<b>1003421</b> AV-06-0078	10	20 Km
<b>1003369</b> AV-06-0043	10	40 Km
<b>1003371</b> AV-06-0044	10	60 Km
<b>1003435</b> AV-06-0085	50	62,5 Km
<b>1003373</b> AV-06-0045	10	70 Km
<b>1003375</b> AV-06-0046	10	80 Km
<b>1003417</b> AV-06-0076	10	90 Km
<b>1003377</b> AV-06-0047	10	100 Km

**Ø 200 mm**

Dischi adesivi di tipo Tedesco segnali di velocità per veicoli omologati in pellicola PVC  
Homologated speed limit self-adhesive discs for vehicles with PVC Film

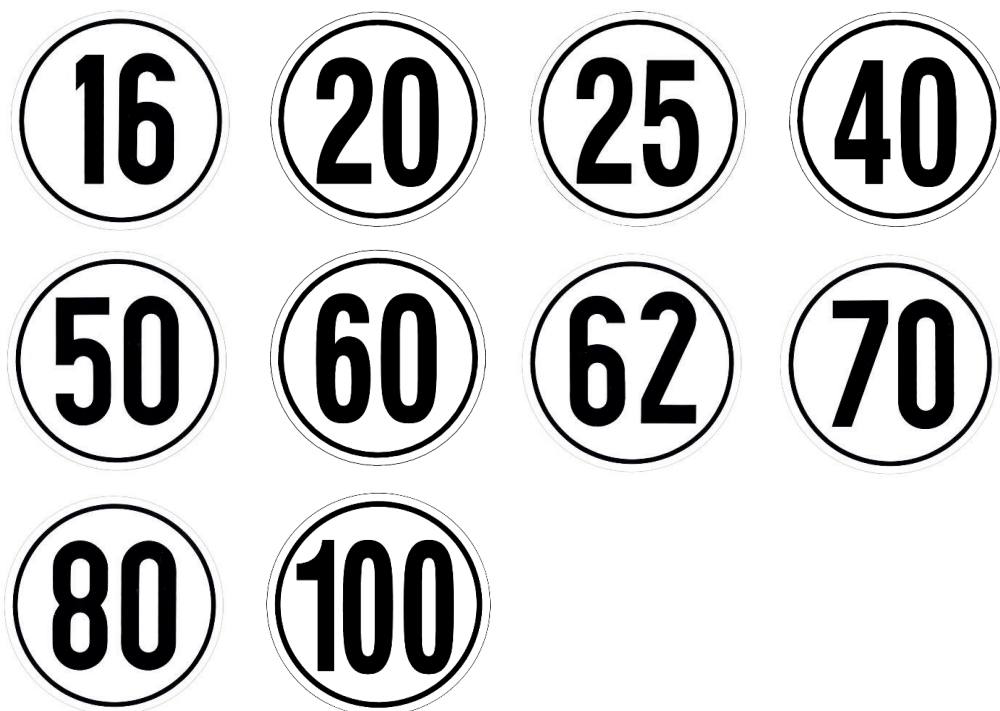

P/N	Q.ta Q.ty	Velocità Speed
<b>1096957</b> AV-06-0111	10	16 Km
<b>1096958</b> AV-06-0112	10	20 Km
<b>1003419</b> AV-06-0077	10	25 Km
<b>1096959</b> AV-06-0113	10	40 Km
<b>1096960</b> AV-06-0114	10	50 Km
<b>1096961</b> AV-06-0115	10	60 Km
<b>1096962</b> AV-06-0116	10	62 Km
<b>1096963</b> AV-06-0117	10	70 Km
<b>1096964</b> AV-06-0118	10	80 Km
<b>1096965</b> AV-06-0119	10	100 Km

### Ø 200 mm

Dischi adesivi di tipo Francese segnali di velocità per veicoli omologati in pellicola PVC  
Homologated speed limit self-adhesive discs for vehicles with PVC Film

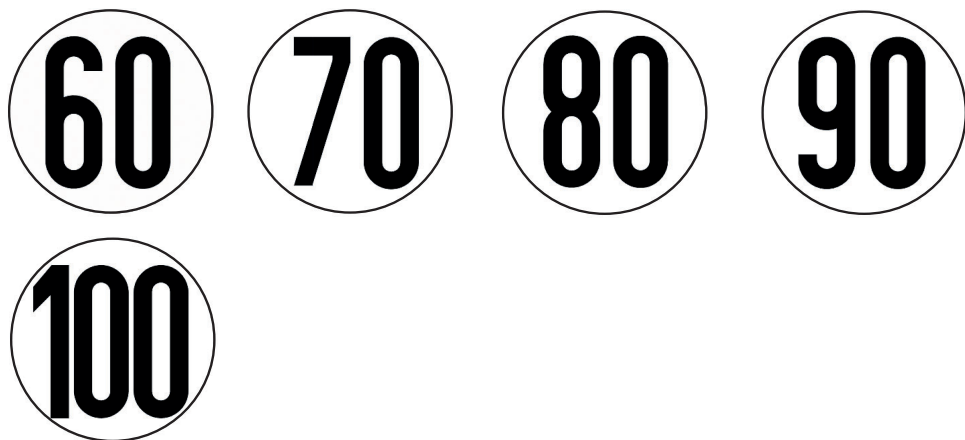

P/N	Q.ta Q.ty	Velocità Speed
<b>1096966</b> AV-06-0120	10	60 Km
<b>1096967</b> AV-06-0121	10	70 Km
<b>1096968</b> AV-06-0122	10	80 Km
<b>1096969</b> AV-06-0123	10	90 Km
<b>1096970</b> AV-06-0124	10	100 Km

### Ø 210 mm

Dischi adesivi di tipo Belga segnali di velocità per veicoli omologati in pellicola rifrangente cl. 1  
Homologated speed limit self-adhesive discs for vehicles with rear reflecting film cl. 1

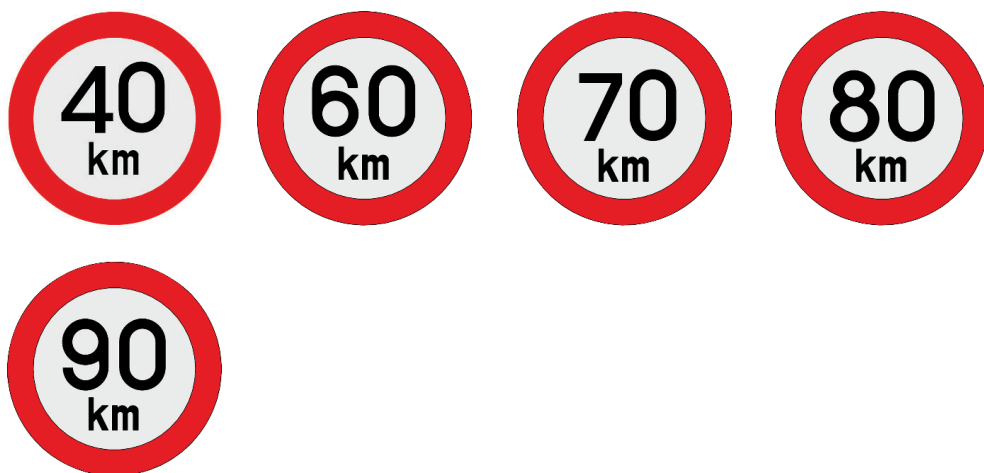

P/N	Q.ta Q.ty	Velocità Speed
<b>1096971</b> AV-06-0125	10	40 Km
<b>1096972</b> AV-06-0126	10	60 Km
<b>1096973</b> AV-06-0127	10	70 Km
<b>1096974</b> AV-06-0128	10	80 Km
<b>1096975</b> AV-06-0129	10	90 Km

### 50 m x 50 mm

Nastri per segnalazioni sagome veicoli superiori alle 3,5 tonnellate conformi ai regolamenti ECE ONU 104 ed ECE 48  
Stripes for over 3,5 tons vehicles marking in conformity with ECE ONU 104 and ECE 48 regulations



Per superfici rigide  
For rigid surface

P/N	Q.ta Q.ty	Colore Color	Lunghezza Length
<b>1003395</b> AV-06-0056	1	●	50 m
<b>1003397</b> AV-06-0057	1	○	50 m
<b>1003399</b> AV-06-0058	1	●	50 m

## 565 x 132 mm

Kit 2 pannelli per motrice, la cui massa è superiore a 3,5 tonnellate  
Kit of 2 panels for tractor with over 3,5 tons weight



R = Retroriflettente- Retroreflective  
F = Fluorescente - Fluorescent

P/N	Q.ta Q.ty	Versione Version	OLD P/N
<b>1003344</b> AV-06-0030	1	Kit 2 pannelli motrice <b>alluminio</b> R/R 1,2 mm. ECE ONU 70 - 01 Kit of 2 <b>aluminium</b> tractor panels R/R 1,2 mm. ECE ONU 70 - 01	
<b>1003346</b> AV-06-0031	1	Kit 2 pannelli motrice <b>alluminio</b> R/F 1,2 mm. ECE ONU 70 - 01 Kit of 2 <b>aluminium</b> tractor panels R/F 1,2 mm. ECE ONU 70 - 01	<b>1016959</b> 06-0233-0000
<b>1003429</b> AV-06-0082	2	Kit 2 pannelli motrice <b>autoadesivo</b> R/F, ECE ONU 70 - 01 Kit of 2 <b>self-adhesive</b> tractor panels R/F, ECE ONU 70 - 01	<b>1003427</b> AV-06-0081
<b>1096952</b> AV-06-0106	10	Kit 2 pannelli motrice <b>alluminio</b> R/R 1,2 mm. ECE ONU 70 - 01 Kit of 2 <b>aluminium</b> tractor panels R/R 1,2 mm. ECE ONU 70 - 01	

## 282,5 x 140 mm

Kit 4 pannelli per motrice, la cui massa è superiore a 3,5 tonnellate  
Kit of 4 panels for tractor with over 3,5 tons weight

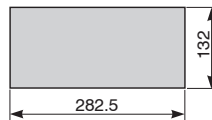

R = Retroriflettente- Retroreflective  
F = Fluorescente - Fluorescent

P/N	Q.ta Q.ty	Versione Version	OLD P/N
<b>1003350</b> AV-06-0033	1	Kit 4 pannelli motrice <b>alluminio</b> R/R 2 mm. ECE ONU 70 - 01 Kit of 4 <b>aluminium</b> tractor panels R/R 2 mm. ECE ONU 70 - 01	
<b>1003352</b> AV-06-0034	1	Kit 4 pannelli motrice <b>alluminio</b> R/F 2 mm. ECE ONU 70 - 01 Kit of 4 <b>aluminium</b> tractor panels R/F 2 mm. ECE ONU 70 - 01	

## 565 x 196 mm

Kit 2 pannelli per rimorchio o semirimorchio, la cui massa è superiore a 3,5 tonnellate  
Kit of 2 panels for trailer or semitrailer with over 3,5 tons weight



R = Retroriflettente- Retroreflective  
F = Fluorescente - Fluorescent

P/N	Q.ta Q.ty	Versione Version	OLD P/N
<b>1003355</b> AV-06-0036	1	Kit 2 pannelli rimorchio <b>alluminio</b> R/R 1,2 mm. ECE ONU 70 - 01 Kit of 2 <b>aluminium</b> trailer panels R/R 1,2 mm. ECE ONU 70 - 01	
<b>1003354</b> AV-06-0035	1	Kit 2 pannelli rimorchio <b>alluminio</b> R/F 1,2 mm. ECE ONU 70 - 01 Kit of 2 <b>aluminium</b> trailer panels R/F 1,2 mm. ECE ONU 70 - 01	<b>1016960</b> 06-0234-0000
<b>1003433</b> AV-06-0084	2	Kit 2 pannelli rimorchio <b>autoadesivo</b> R/F ECE ONU 70 - 01 Kit of 2 <b>self-adhesive</b> trailer panels R/F ECE ONU 70 - 01	<b>1003431</b> AV-06-0083
<b>1096953</b> AV-06-0107	10	Kit 2 pannelli rimorchio <b>alluminio</b> R/R 1,2 mm. ECE ONU 70 - 01 Kit of 2 <b>aluminium</b> trailer panels R/R 1,2 mm. ECE ONU 70 - 01	

### 282,5 x 196 mm

Kit 4 pannelli per rimorchio o semirimorchio, la cui massa è superiore a 3,5 tonnellate  
*Kit of 4 panels for trailer or semitrailer with over 3,5 tons weight*

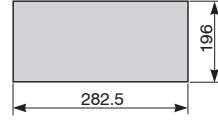
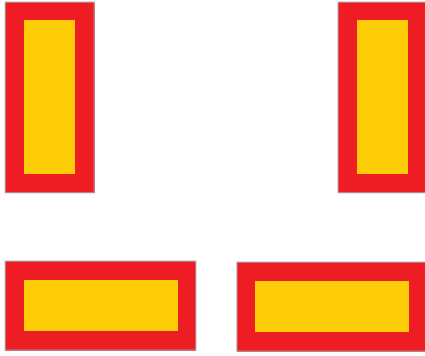

R = Retroriflettente - *Retroreflective*  
F = Fluorescente - *Fluorescent*

P/N	Q.ta Q.ty	Versione Version
<b>1003359</b> AV-06-0038	1	Kit 4 pannelli rimorchio <b>alluminio</b> R/R 2 mm. ECE ONU 70 - 01 <i>Kit of 4 aluminium trailer panels R/R 2 mm. ECE ONU 70 - 01</i>
<b>1003361</b> AV-06-0039	1	Kit 4 pannelli rimorchio <b>alluminio</b> R/F 2 mm. ECE ONU 70 - 01 <i>Kit of 4 aluminium trailer panels R/F 2 mm. ECE ONU 70 - 01</i>

### 564 x 140 mm

Kit 2 pannelli retroriflettenti e fluorescenti per attrezzature portate o semiportate dalle trattrici agricole  
*Kit of 2 fluorescent and retroreflective panels for implements carried by agricultural vehicles*



P/N	Q.ta Q.ty
<b>1016961</b> 06-0235-0000	2

### 423 x 423 mm

Pannello retroriflettente e fluorescente per attrezzature portate o semiportate dalle trattrici agricole  
*Fluorescent and retroreflective panel for implements carried by agricultural vehicles*

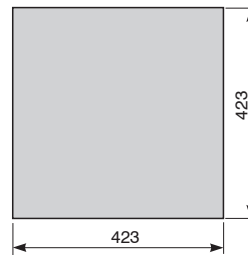

P/N	Q.ta Q.ty
<b>1016962</b> 06-0236-0000	2

### 410 x 356 mm

Pannello retroriflettente in alluminio per veicoli agricoli lenti, 1,5 mm  
*Retroreflective aluminium panel for slow agricultural vehicles, 1,5 mm*

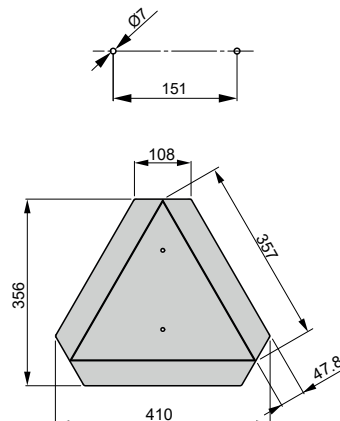
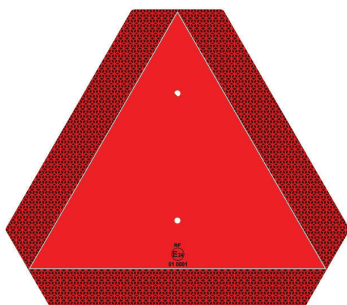

P/N	Q.ta Q.ty
<b>1096938</b> AV-06-0093	10

### 500 x 500 mm

Pannello alluminio per carichi sporgenti (tipo Italiano), 1 mm  
Aluminium panel for oversize loads (Italian type), 1 mm

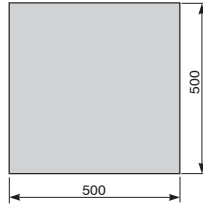

P/N	Q.ta Q.ty
<b>1016963</b> 06-0237-0000	1
<b>1096951</b> AV-06-0130	10

### 500 x 500 mm

Pannello alluminio per carichi sporgenti (tipo Spagnolo), 1,4 mm  
Aluminium panel for oversize loads (Spanish type), 1,4 mm

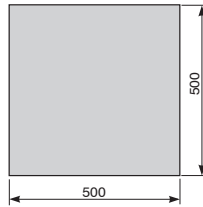

P/N	Q.ta Q.ty
<b>1003363</b> AV-06-0040	1

### 600 x 300 mm

Kit 2 pannelli alluminio per trasporti eccezionali, 2 mm  
Kit of 2 aluminium panels for exceeding loads transport, 2 mm

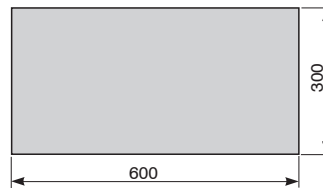

P/N	Q.ta Q.ty
<b>1003365</b> AV-06-0041	1

### 282 x 282 mm

Kit 2 pannelli / adesivi segnalazione attrezzature agricole, 1 mm  
Kit of 2 panels / adhesive indicating agricultural equipment, 1 mm

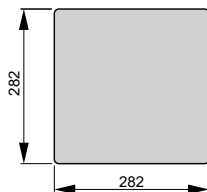

P/N	Q.ta Q.ty	Versione Version
<b>1096939</b> AV-06-0094	10	Kit 2 adesivi per attrezzature agricole, REG. R104 - Classe F Kit of 2 adhesive for agricultural equipment, REG. R104 - F Class
<b>1096944</b> AV-06-0099	10	Kit 2 pannelli alluminio, conformi al regolamento ECE REG NR 104 C, 1 mm Kit of 2 aluminium panel, compliant to the ECE REG NR 104 C regulation, 1 mm
<b>1096955</b> AV-06-0109	10	Kit 2 pannelli alluminio, conformi al regolamento ECE 70 Classe 5, 1 mm Kit of 2 aluminium panel, compliant to the ECE 70 5 Class regulation, 1 mm

### 423 x 423 mm

Kit 2 pannelli / adesivi segnalazione attrezzature agricole, 1 mm  
Kit of 2 panels / adhesive indicating agricultural equipment, 1 mm

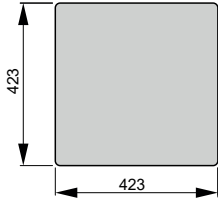

P/N	Q.ta Q.ty	Versione Version
<b>1088095</b> 06-0266-0000	10	Kit 2 pannelli alluminio, TP ESC / DIN 11030, <b>1 mm</b> Kit of 2 aluminium panels, TP ESC / DIN 11030, <b>1 mm</b>
<b>1096940</b> AV-06-0095	10	Kit 2 adesivi retroriflettenti, REG. R104 - Classe F Kit of 2 retroreflective adhesive, REG. R104 - F Class
<b>1096945</b> AV-06-0100	10	Kit 2 pannelli alluminio, RA2 NBN EN 12899-1, <b>1 mm</b> Kit of 2 aluminium panels, RA2 NBN EN 12899-1, <b>1 mm</b>

### 423 x 423 mm

Kit 2 pannelli segnalazione attrezzature agricole  
Kit of 2 panels indicating agricultural equipment

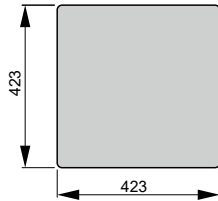

P/N	Q.ta Q.ty	Versione Version
<b>1089834</b> AV-06-0086	10	Kit 2 pannelli alluminio, ECE 70 Classe 5, <b>1 mm</b> Kit of 2 aluminium panels, ECE 70 Class 5 regulation, <b>1 mm</b>
<b>1089835</b> AV-06-0087	10	Kit 2 pannelli alluminio, ECE 70 Classe 5, <b>2 mm</b> Kit of 2 aluminium panels, ECE 70 Class 5 regulation, <b>2 mm</b>

### 423 x 282 mm

Kit 2 pannelli 1 mm  
Kit of 2 panels 1 mm

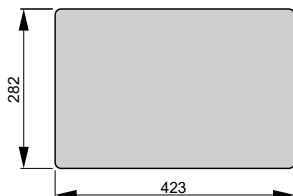

P/N	Q.ta Q.ty	Versione Version
<b>1095130</b> AV-06-0092	10	Adesivo destro, REG. R104 Classe F RH adhesive, REG. R104 Class F
<b>1096941</b> AV-06-0096	10	Kit 2 adesivi, REG. R104 - Classe F, ORALITE 5921M Kit of 2 adhesive, REG. R104 - F Class, ORALITE 5921M
<b>1096956</b> AV-06-0110	10	Kit 2 pannelli alluminio, ECE 70 Classe 5, <b>1 mm</b> Kit of 2 aluminium panels, ECE 70 Class 5, <b>1 mm</b>
<b>1088097</b> 06-0267-0000	10	Kit 2 pannelli alluminio, TP ESC / DIN 11030, <b>1 mm</b> Kit of 2 aluminium panels, TP ESC / DIN 11030, <b>1 mm</b>

### 423 x 141 mm

Kit 2 adesivi, REG. R104 - Classe F, ORALITE 5921M  
Kit of 2 adhesive, REG. R104 - F Class, ORALITE 5921M

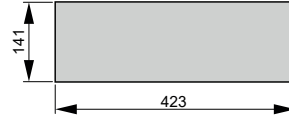
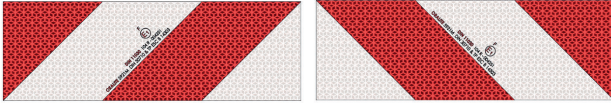

P/N	Q.ta Q.ty
<b>1096943</b> AV-06-0098	10

### 560 x 282 mm

Kit 2 pannelli alluminio segnalazione attrezzature agricole, RA2 NBN EN 12899-1, 1 mm  
Kit of 2 agricultural equipment signaling aluminium panels, RA2 NBN EN 12899-1, 1 mm

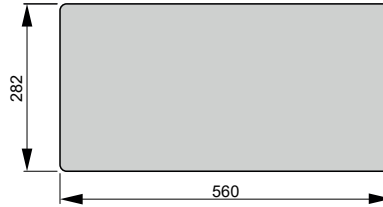

P/N	Q.ta Q.ty
<b>1096946</b> AV-06-0101	10

### 800 x 141 mm

Kit 2 pannelli alluminio segnalazione attrezzature agricole, RA2 NBN EN 12899-1, 1 mm  
Kit of 2 agricultural equipment signaling aluminium panels, RA2 NBN EN 12899-1, 1 mm

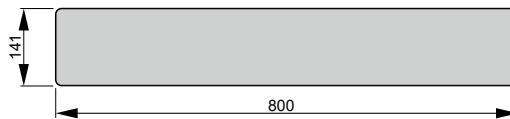

P/N	Q.ta Q.ty
<b>1096947</b> AV-06-0102	10

### 846 x 141 mm

Kit 2 adesivi segnalazione attrezzature agricole, REG. R104 - Classe F, ORALITE 5921M  
Kit of 2 adhesive agricultural equipment signaling, REG. R104 - F Class, ORALITE 5921M

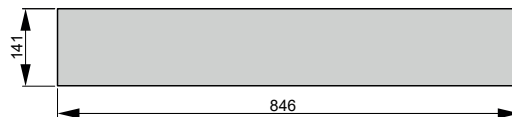
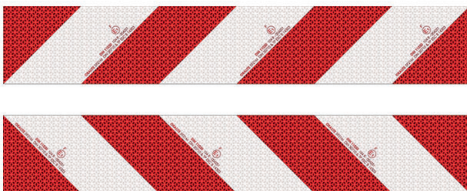

P/N	Q.ta Q.ty
<b>1096942</b> AV-06-0097	10



## 320 x 160 mm

Adesivi in PVC  
PVC adhesive

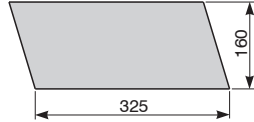
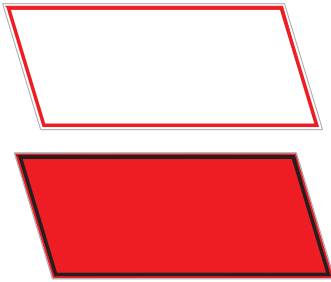

P/N	Q.ta Q.ty	Versione Version
<b>1003423</b> AV-06-0079	10	Adesivo in PVC bianco, cornice rossa, per veicoli conto terzi <i>White PVC adhesive, red bezel, for third party load transport</i>
<b>1003425</b> AV-06-0080	10	Adesivo in PVC rosso, cornice nera, per veicoli conto proprio <i>Red PVC adhesive, black bezel, for owner's load transport</i>

## 1200 x 400 mm

Pannello in alluminio "CONVOI AGRICOLE", 1 mm  
*Aluminium panel "CONVOI AGRICOLE", 1 mm*

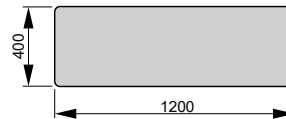

P/N	Q.ta Q.ty
<b>1096950</b> AV-06-0105	10

## 400 x 300 mm / 300 x 120 mm

Pannelli generici pieghevoli verticali  
*Vertical folding neutral panels*

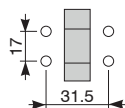
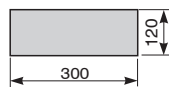
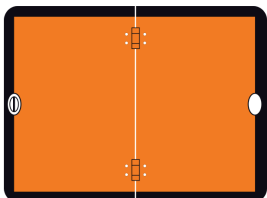
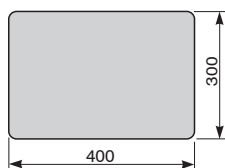
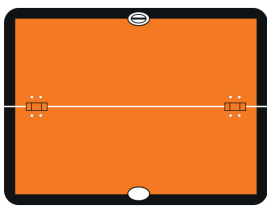

P/N	Q.ta Q.ty	Versione Version
<b>1096954</b> AV-06-0108	5	Pannello generico pieghevole orizzontale ADR, <b>alluminio 1 mm</b> per segnalazione trasporto merci pericolose <i>Horizontal folding neutral panel ADR, aluminium 1 mm for dangerous load transport 400 x 300 mm</i>
<b>1003385</b> AV-06-0051	1	Pannello generico pieghevole verticale ADR, <b>alluminio 1 mm</b> per segnalazione trasporto merci pericolose <i>Vertical folding neutral panel ADR, aluminium 1 mm for dangerous load transport 400 x 300 mm</i>
<b>1003381</b> AV-06-0049	1	Pannello generico pieghevole verticale ADR, <b>alluminio 2 mm</b> per segnalazione trasporto merci pericolose <i>Vertical folding neutral panel ADR, aluminium 2 mm for dangerous load transport 300 x 120 mm</i>

## 400 x 300 mm / 300 x 120 mm

Pannelli generici fissi  
Standard fixed neutral panels

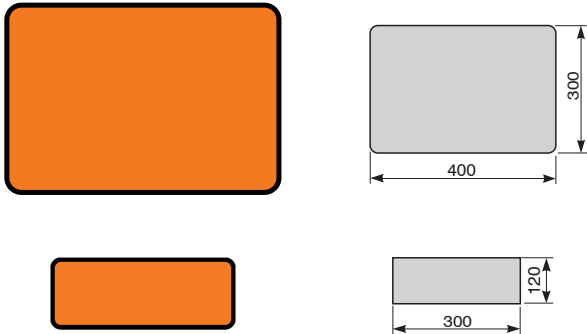

P/N	Q.ta Q.ty	Versione Version
<b>1003379</b> AV-06-0048	1	Pannello generico fisso ADR zincato 0,8 mm per segnalazione trasporto merci pericolose. Standard fixed neutral panel ADR, zinc-plated 0,8 mm, for dangerous load transport 400 x 300 mm
<b>1003383</b> AV-06-0050	1	Pannello generico fisso ADR alluminio 1 mm per segnalazione trasporto merci pericolose Standard fixed neutral panel ADR, aluminium 1 mm for dangerous load transport 300 x 120 mm

## 500 x 400 mm

Adesivi trasporti prodotti deperibili  
Self-adhesive for perishable products load transport

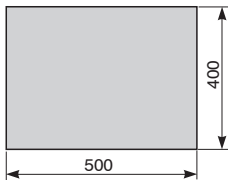

P/N	Q.ta Q.ty	Versione Version
<b>1003387</b> AV-06-0052	10	Adesivo lettera "a" per trasporto prodotti agricoli deperibili Self-adhesive letter "a" for perishable agricultural load transport
<b>1003389</b> AV-06-0053	10	Adesivo lettera "d" per trasporto prodotti alimentari deperibili Self-adhesive letter "d" for perishable good load transport

## 400 x 400 mm / 150 x 150 mm

Adesivi lettera "R" contrassegno per veicolo raccolta, trasporto rifiuti urbani  
Self-adhesive letter "R" for waste material load transport

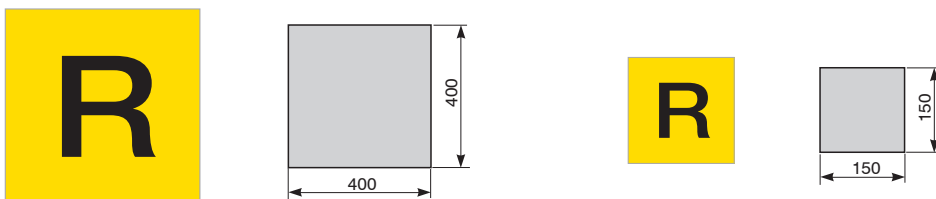

P/N	Q.ta Q.ty	Dimensione Dimension
<b>1003391</b> AV-06-0054	10	400 x 400 mm
<b>1003393</b> AV-06-0055	10	150 x 150 mm

### 470 x 200 x h230 mm

Calzatoia DIN 76051 / E53  
Wheel chock DIN 76051 / E53

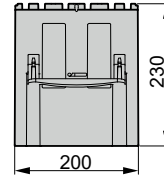
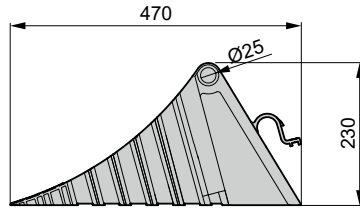

P/N	Q.ta Q.ty
<b>1096976</b> AV-34-0196	2

### 380 x 160 x h190 mm

Calzatoia media DIN 76051 / E46  
Medium wheel chock DIN 76051 / E46

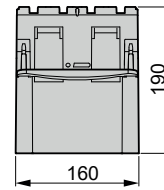
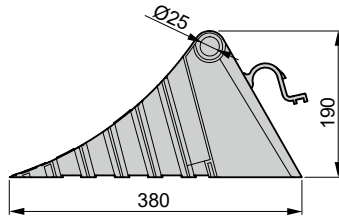
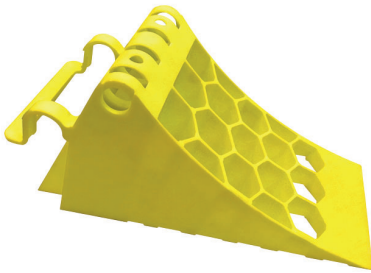

P/N	Q.ta Q.ty
<b>1096978</b> AV-34-0198	2

### 289 x 111 mm

Supporto in plastica per calzatoia E53  
Plastic holder for E53 wheel chock

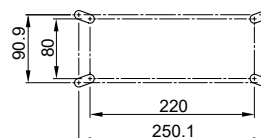
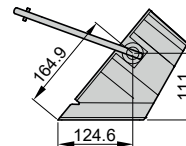
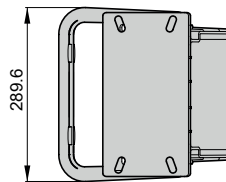

P/N	Q.ta Q.ty
<b>1096977</b> AV-34-0197	2

pagina <i>page</i>	pagina <i>page</i>	pagina <i>page</i>	pagina <i>page</i>	pagina <i>page</i>	pagina <i>page</i>
1003344 . . . . . 4	1095130 . . . . . 7				
1003346 . . . . . 4	1096938 . . . . . 5				
1003350 . . . . . 4	1096939 . . . . . 6				
1003352 . . . . . 4	1096940 . . . . . 7				
1003354 . . . . . 4	1096941 . . . . . 7				
1003355 . . . . . 4	1096942 . . . . . 8				
1003359 . . . . . 5	1096943 . . . . . 8				
1003361 . . . . . 5	1096944 . . . . . 6				
1003363 . . . . . 6	1096945 . . . . . 7				
1003365 . . . . . 6	1096946 . . . . . 8				
1003367 . . . . . 2	1096947 . . . . . 8				
1003369 . . . . . 2	1096950 . . . . . 9				
1003371 . . . . . 2	1096951 . . . . . 6				
1003373 . . . . . 2	1096952 . . . . . 4				
1003375 . . . . . 2	1096953 . . . . . 4				
1003377 . . . . . 2	1096954 . . . . . 9				
1003379 . . . . . 10	1096955 . . . . . 6				
1003381 . . . . . 9	1096956 . . . . . 7				
1003383 . . . . . 10	1096957 . . . . . 2				
1003385 . . . . . 9	1096958 . . . . . 2				
1003387 . . . . . 10	1096959 . . . . . 2				
1003389 . . . . . 10	1096960 . . . . . 2				
1003391 . . . . . 10	1096961 . . . . . 2				
1003393 . . . . . 10	1096962 . . . . . 2				
1003395 . . . . . 3	1096963 . . . . . 2				
1003397 . . . . . 3	1096964 . . . . . 2				
1003399 . . . . . 3	1096965 . . . . . 2				
1003417 . . . . . 2	1096966 . . . . . 3				
1003419 . . . . . 2	1096967 . . . . . 3				
1003421 . . . . . 2	1096968 . . . . . 3				
1003423 . . . . . 9	1096969 . . . . . 3				
1003425 . . . . . 9	1096970 . . . . . 3				
1003427 . . . . . 4	1096971 . . . . . 3				
1003429 . . . . . 4	1096972 . . . . . 3				
1003431 . . . . . 4	1096973 . . . . . 3				
1003433 . . . . . 4	1096974 . . . . . 3				
1003435 . . . . . 2	1096975 . . . . . 3				
1016959 . . . . . 4	1096976 . . . . . 11				
1016960 . . . . . 4	1096977 . . . . . 11				
1016961 . . . . . 5	1096978 . . . . . 11				
1016962 . . . . . 5					
1016963 . . . . . 6					
1088095 . . . . . 7					
1088097 . . . . . 7					
1089834 . . . . . 7					
1089835 . . . . . 7					

<i>pagina</i> <i>page</i>	<i>pagina</i> <i>page</i>	<i>pagina</i> <i>page</i>	<i>pagina</i> <i>page</i>	<i>pagina</i> <i>page</i>	<i>pagina</i> <i>page</i>
06-0233-0000 . . . 4	AV-06-0092. . . . 7				
06-0234-0000 . . . 4	AV-06-0093. . . . 5				
06-0235-0000 . . . 5	AV-06-0094. . . . 6				
06-0236-0000 . . . 5	AV-06-0095. . . . 7				
06-0237-0000 . . . 6	AV-06-0096. . . . 7				
06-0266-0000 . . . 7	AV-06-0097. . . . 8				
06-0267-0000 . . . 7	AV-06-0098. . . . 8				
AV-06-0030. . . . 4	AV-06-0099. . . . 6				
AV-06-0031. . . . 4	AV-06-0100. . . . 7				
AV-06-0033. . . . 4	AV-06-0101. . . . 8				
AV-06-0034. . . . 4	AV-06-0102. . . . 8				
AV-06-0035. . . . 4	AV-06-0105. . . . 9				
AV-06-0036. . . . 4	AV-06-0106. . . . 4				
AV-06-0038. . . . 5	AV-06-0107. . . . 4				
AV-06-0039. . . . 5	AV-06-0108. . . . 9				
AV-06-0040. . . . 6	AV-06-0109. . . . 6				
AV-06-0041. . . . 6	AV-06-0110. . . . 7				
AV-06-0042. . . . 2	AV-06-0111. . . . 2				
AV-06-0043. . . . 2	AV-06-0112. . . . 2				
AV-06-0044. . . . 2	AV-06-0113. . . . 2				
AV-06-0045. . . . 2	AV-06-0114. . . . 2				
AV-06-0046. . . . 2	AV-06-0115. . . . 2				
AV-06-0047. . . . 2	AV-06-0116. . . . 2				
AV-06-0048. . . . 10	AV-06-0117. . . . 2				
AV-06-0049. . . . 9	AV-06-0118. . . . 2				
AV-06-0050. . . . 10	AV-06-0119. . . . 2				
AV-06-0051. . . . 9	AV-06-0120. . . . 3				
AV-06-0052. . . . 10	AV-06-0121. . . . 3				
AV-06-0053. . . . 10	AV-06-0122. . . . 3				
AV-06-0054. . . . 10	AV-06-0123. . . . 3				
AV-06-0055. . . . 10	AV-06-0124. . . . 3				
AV-06-0056. . . . 3	AV-06-0125. . . . 3				
AV-06-0057. . . . 3	AV-06-0126. . . . 3				
AV-06-0058. . . . 3	AV-06-0127. . . . 3				
AV-06-0076. . . . 2	AV-06-0128. . . . 3				
AV-06-0077. . . . 2	AV-06-0129. . . . 3				
AV-06-0078. . . . 2	AV-06-0130. . . . 6				
AV-06-0079. . . . 9	AV-34-0196. . . . 11				
AV-06-0080. . . . 9	AV-34-0197. . . . 11				
AV-06-0081. . . . 4	AV-34-0198. . . . 11				
AV-06-0082. . . . 4					
AV-06-0083. . . . 4					
AV-06-0084. . . . 4					
AV-06-0085. . . . 2					
AV-06-0086. . . . 7					
AV-06-0087. . . . 7					

## Note / Notes

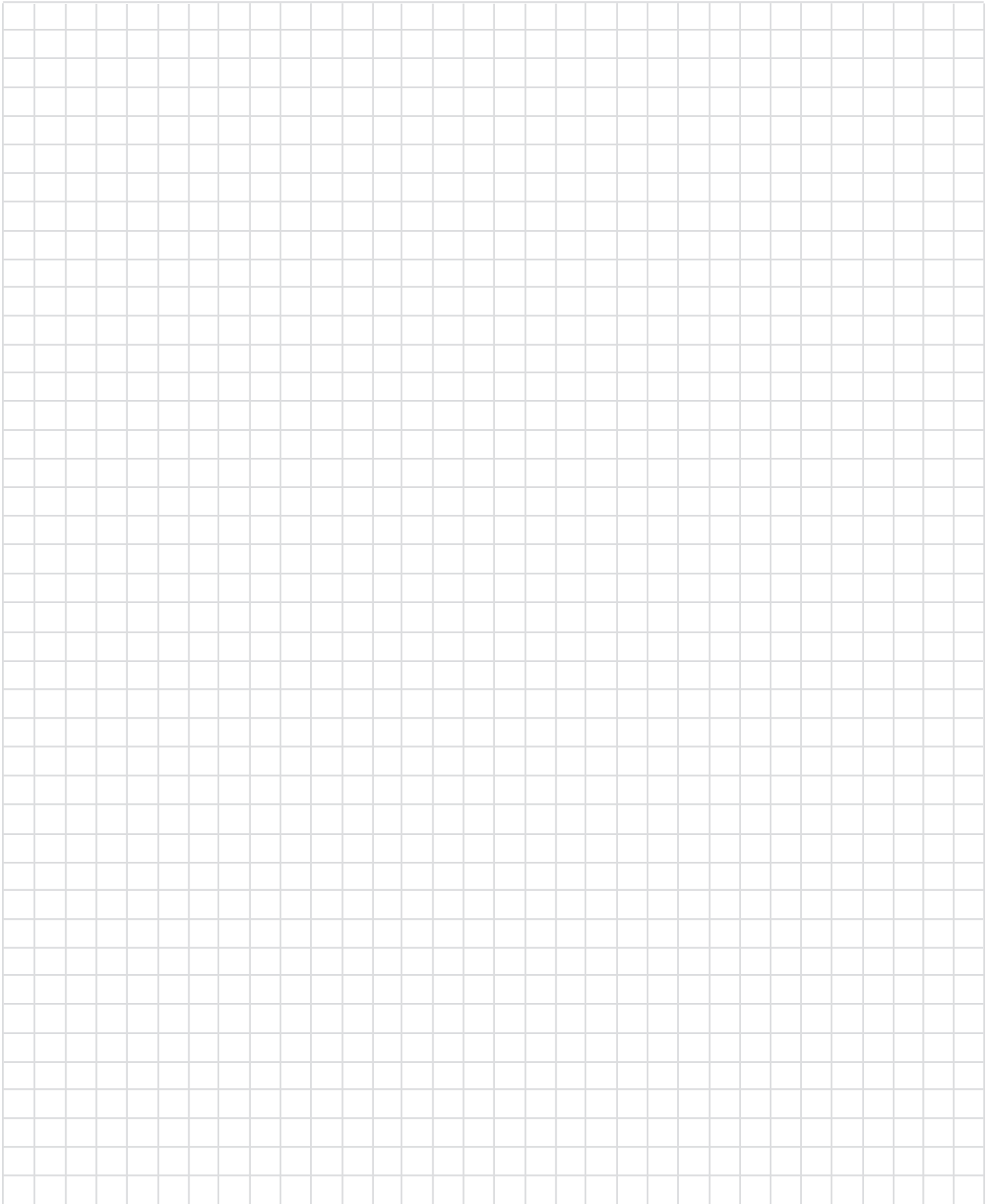

## Note / Notes

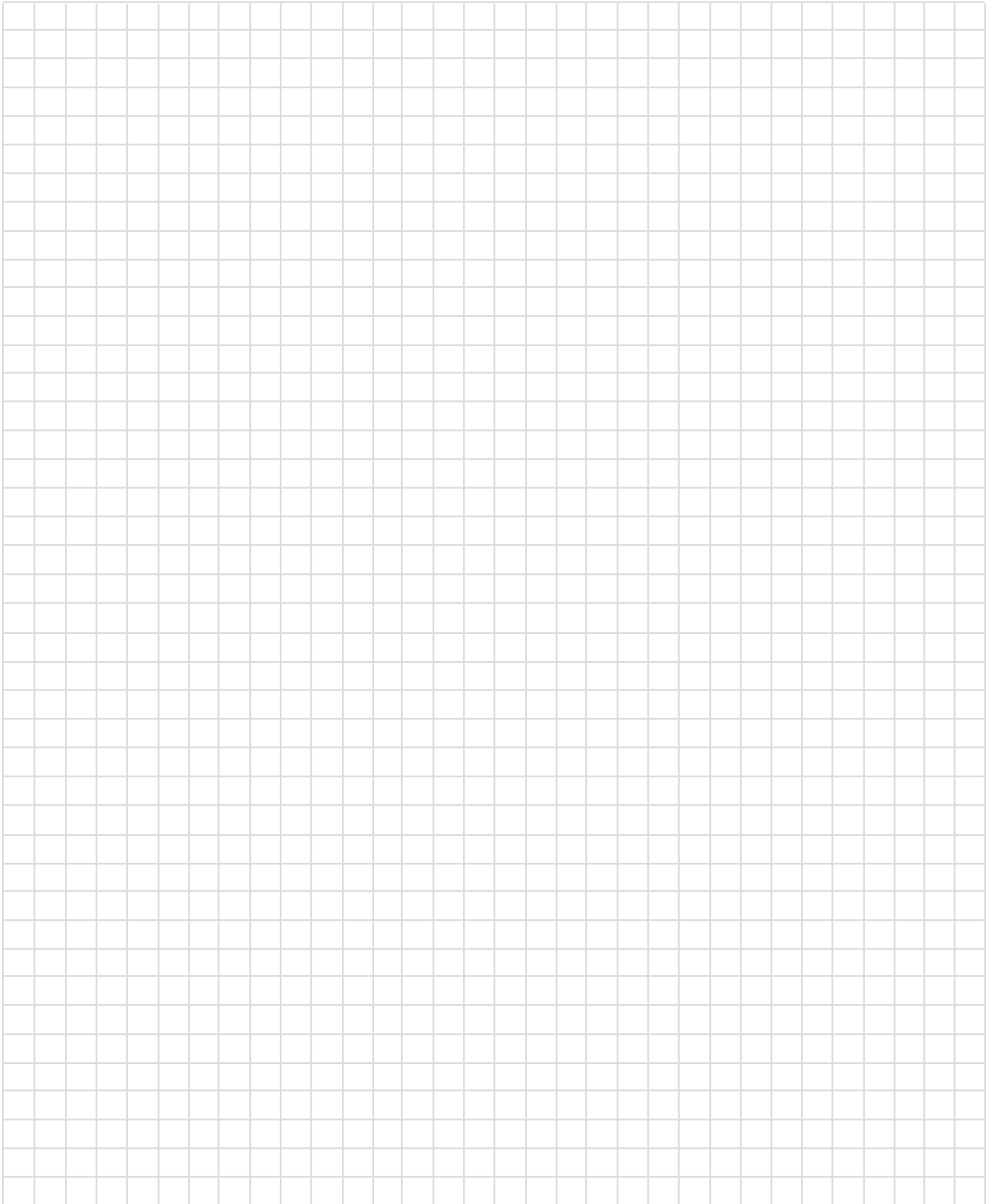

**GERMANY**

**COBO DEUTSCHLAND GmbH**  
Zum Schürmannsgraben, 12E  
D-47441 - Moers  
Germany  
Phone: +49 (0) 2841 88238 0  
Fax: +49 (0) 2841 88238 23  
E-mail: [info@cobogroup.net](mailto:info@cobogroup.net)  
Web Site: [www.cobo-deutschland.com](http://www.cobo-deutschland.com)

**FRANCE**

**COBO FRANCE Sarl**  
Allée de l'Europe, 2 - Zone Coriolis  
71210 - Ecuisses  
France  
Phone: +33 (0) 3 857 30560  
Fax: +33 (0) 3 857 85606  
E-mail: [info@cobogroup.net](mailto:info@cobogroup.net)  
Web Site: [www.cobofrance.com](http://www.cobofrance.com)

**NORTH AMERICA**

**COBO USA Corporation**  
West Division Street, 304  
52655 - West Burlington  
Iowa - Usa  
Phone: +1 319 754 5585  
Fax: +1 319 754 8724  
E-mail: [info@cobogroup.net](mailto:info@cobogroup.net)  
Web Site: [www.cobointernational.com](http://www.cobointernational.com)

**LATIN AMERICA**

**COBO COMPONENTES AGR. E IND. Ltda**  
Rua Dona Francisca, 8300 - Bloco 9-C  
89219-600 Zona Industrial - Joinville  
Santa Catarina - Brasil  
Phone: +55 47 3305 0095  
E-mail: [info@cobogroup.net](mailto:info@cobogroup.net)  
Web Site: [www.cobogroup.net](http://www.cobogroup.net)

**OCEANIA**

**COBO OCEANIA Ltd**  
Burnside Road, 9/93  
4207 Stapylton - Brisbane  
Queensland - Australia  
Phone: +61 (0) 7 3807 4866  
Fax: +61 (0) 7 3807 6780  
E-mail: [info@cobogroup.net](mailto:info@cobogroup.net)  
Web Site: [www.cobo.com.au](http://www.cobo.com.au)

**SOUTH-EAST ASIA**

**COBO ASIA Ltd**  
Heung Yip Road, 2 - One Island South  
622 6/F Unit - Wong Chuk Hang  
Hong Kong  
Phone: +852 3590 3588  
Fax: +852 3590 3566  
E-mail: [info@cobogroup.net](mailto:info@cobogroup.net)  
Web Site: [www.cobogroup.net](http://www.cobogroup.net)

**CHINA**

**COBO GUANGZHOU Ltd**  
Qiaotou Street, 226 - Beishan - Haizhu  
51000 - Guangzhou  
People's Republic of China  
Phone: +86 20 8922 5611  
Fax +86 20 8922 5635  
E-mail: [info@cobogroup.net](mailto:info@cobogroup.net)  
Web Site: [www.cobochina.com](http://www.cobochina.com)

**INDIA**

**COBO INDIA Branch Office**  
Mathura Road, 13/6 - 2nd floor, 205  
121003 NH-2 - Faridabad  
Haryana - India  
Phone: +91 129 4871206  
Email: [info@cobogroup.net](mailto:info@cobogroup.net)  
Web Site: [www.cobogroup.net](http://www.cobogroup.net)

**C.O.B.O. SpA**

Via Tito Speri, 10  
25024 Leno (Brescia) ITALY  
Phone +39 030 90451  
Fax +39 030 9045330



[info@cobogroup.net](mailto:info@cobogroup.net) | [www.cobogroup.net](http://www.cobogroup.net)